

CLEMENT

The Value Leader in the Dump Trailer Industry!

Frameless Rock Trailer



The RockStar Frameless Rock Trailer

RockStar has proven "on the ground" experience.

Clement's Frameless RockStar has become the standard for which other trailers are now judged. Whether it's 14-ton boulders, 2-ton rip-rap, or even shot rock, Clement Rock Trailers have handled the loads with efficiency. They are also adept at handling more conventional loads like sand and gravel, liquids, concrete and asphalt. This outstanding track record is the result of Clement's outstanding engineering and the experience gained from thousands of rock trailers in the field.

5" round, 25-000lb. axles in combination with hub-piloted wheels

Proven on hundreds of thousands of trailers, 25,000 -lb. axles feature common inner and outer bearings. Combined with parallel spindle, both axle & bearing life are substantially increased. With hub-piloted wheels there are no inner nuts; all nuts have right-hand threads, which reduces maintenance time and cost.

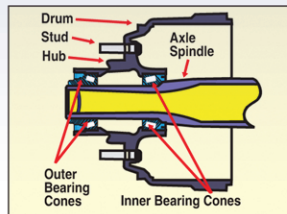

Multiple applications

RockStar's standard body shell is made of 1/4-inch AR450. AR450 steel is the highest strength steel that technology can provide for dump trailers; with 32% greater yield strength and 36% greater tensile strength than AR400 steel.

The RockStar is capable of withstanding severe impact loads, as well as normally anticipated loads such as sand, gravel, coal, scrap and demolition, etc.



RockStar's inverted cylinder

Inverted cylinders have no doghouse to interfere with the load, and since the king pin is located forward, the bridge length is longer allowing greater gross weight. Inverted cylinders have no ledges to collect dirt and contaminate the system. Externally mounted, they are easier to service and faster to remove.



RockStar's Air-lift gate

The RockStar standard air-lift gate has a clearance of 32-inches of lift-height over trailer side-height. With the capacity of the opening this greatly improves discharge from the trailer.

*(gate opening sizes on spec sheet)

Mud flaps are attached to the tailgate to reduce flap damage.



Dumps with wheels on the ground

The RockStar dump trailers dump with wheels on the ground, except when folding stop blocks are ordered for the trailer.

RockStar=

- Dependability
- Profitability
- Strength
- Longevity
- Stability
- Volume

CLEMENT

P. O. Box 914 • Minden, LA • 71058-0914 • 800-562-5948
www.clementind.com Contact by e-mail: sales@clementind.com

Specifications

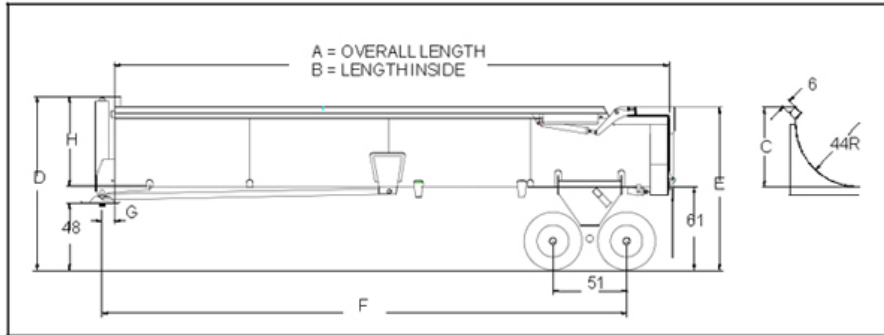

Photo may include options

The RockStar Half-Round Frameless Rock Trailer

MODEL	Specifications					Dimensions							
	CAPACITY	AIR-LIFT GATE OPENING	HOIST	DUMP ANGLE	WT TOTAL	A	B	C	D	E	F	G	H
ROCKSTAR2626	26	87"	85-220T 30 Ton	45°	12,270	28'5"	26'0"	55"	117"	109"	293"	-8.5"	60"
ROCKSTAR2828	28	87"	85-220T 30 Ton	45°	13,091	30'5"	28' 0"	55"	123"	113"	315"	-8.5"	63"
ROCKSTAR3232	32	87"	85-235T 30 Ton	45°	13,900	34'5"	32' 0"	55"	120"	112"	365"	-8.5"	63"
ROCKSTAR3434	34	87"	85-250T 30 Ton	45°	14,058	35'8"	34'0"	55"	126"	113"	389"	-8.5"	65"
ROCKSTAR3730	30	77"	85-280T 30 Ton	45°	14,650	39'5"	37'0"	45"	110"	102"	425"	-8.5"	53"

GENERAL SPECIFICATIONS:

CHASSIS

- Suspension: 50,000 # Single Point - 3 Leaf
- Axles: (2) 102", 5/8 Wall, 5" Round, Common Inner/Outer Bearings
- Wheels: 8.25 x 24.5, 10 Hole Hub-Piloted Disc
- Tires: 11 x 24.5 Radial
- Hubs: 10 Hole Pilot Hub
- Brakes: Air 16 1/2" x 7" Outboard Cast Drum;
- ABS: 2S 1M
- Axle Spacing: 51"
- Lights: 12 Volt Sealed Beam, Rubber Grommet
- Back-up Alarm: Yes
- Mud Flaps: Rubber Rear oNLY
- Wiring: Sealed Harness Modular Plug In
- Draft Arms: 3" x 4" x 1/8 Tubing
- King Pin Plate: 1/4" AR450 (Rocking/Breakaway)

BODY

- Type: Steel Frameless Tandem Axle Semi-end Dump
- Tailgate: Top Hinged, Air Lift 3/16" AR450 Abrasion Resistance Steel
- Body Shell: 3/4" AR450 Abrasion Resistance Steel
- Front: 1/2" AR450 Abrasion Resistance Steel
- Paint: One color urethane enamel over primed surface
- Longitudinal: none
- Top Rail: 6" x 6" x 1/4" Tubing
- Rear Corner Posts: 3/16" HT50
- Hoist Housing: None - Inverted Trunnion Mount Hoist

- Common Options:**
- Electric Flip Tarp
 - Front Fenders
 - Aluminum Wheels

Custom Options Available