

RollStar XS: *strong, powerful and extremely maneuverable*



RollStar XS's frameless design is strong, and durable without the payload-robbing weight of frame roll-offs.

- Trailer length is 28-feet in the down position.
- XS is 22.5-feet in length, fully raised (*from the kingpin to the rear of the trailer*) which results in a very tight turn radius and efficiency in tight areas.
- 57-inch deck height (*with a 47-inch high fifth wheel*)
- Legally haul 105-inch compactor containers at a total vehicle height under 13-feet, 6-inches.
- Trailer weight – 12,800-pounds +/- 3%

88,000-pound hoist lifting capacity

- The RollStar XS has dual reeving cylinders with a lift capacity of 54,000-pounds at 45-degrees.
- Reeving cylinders have a cycle time of 1.5 minutes.

Single Point Spring ride 50K Tandem Fixed (26-foot Air Ride version is also available.)

RollStar XS has a legal payload of 45,000-pounds
subject to local, state and federal regulations.

The RollStar XS has been designed and constructed to be extremely effective in very tight spaces.

**RollStar XS's strength, maneuverability and versatility
wil result in greater profits from your
your time and investment.**

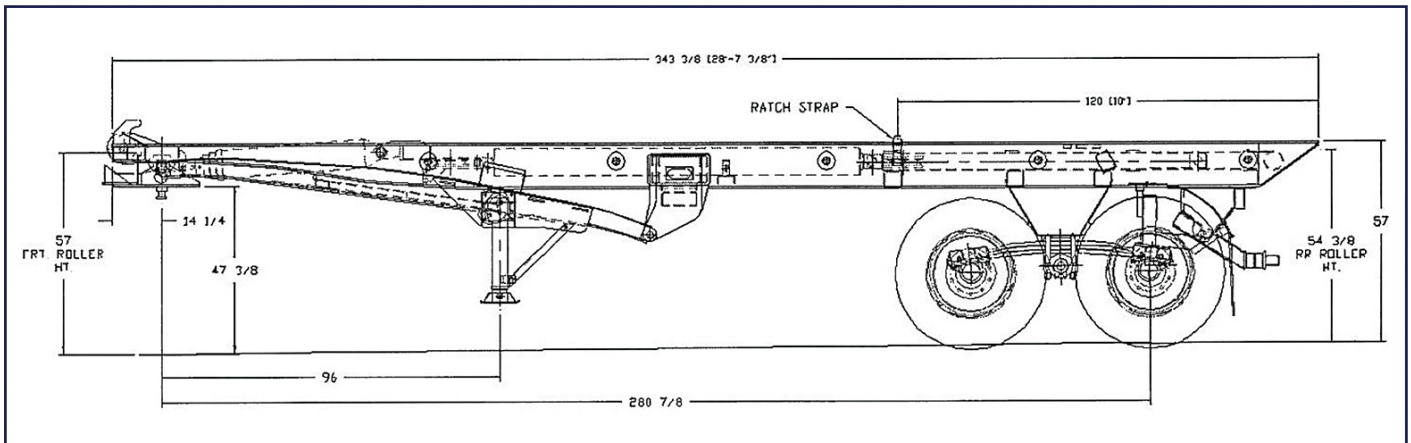

RollStar XS General Specifications

Dump Angle	Overall Length	Rear Roller Height	Rail Height Front	Kingpin Location	Kingpin to Rear Axle
45 degrees	343"	54-3/8"	57-1/16"	14-1/4"	280-7/8"

Chassis

- Suspension:** 50,000-pound, single point, 3-leaf
- Axles:** (2) 102-inch, 25,000-pound, 5-inch round, common inner/outer bearings
- Wheels:** 8.25-inch x 24.5-inch, hub-piloted disc
- Hubs:** 10-hole pilot hub
- Tires:** 11R 24.5
- Brakes:** Air 16-1/2-inch x 7-inch cast drum
- ABS:** 2S1M
- Paint:** One color urethane enamel over urethane primed surface
- Lights:** Sealed beam rubber grommet
- Wiring:** Sealed harness, 7 wire
- Mud Flaps:** Rear only
- King Pin Plate:** 3/4-inch (Rocking)
- Back Up Alarm:** Yes
- Rear Impact Guard:** Yes (Extended tail only)

Hydraulic Controls

Double acting control valve on king-pin plate – for operating from ground (this requires standard single line wet kit plus one return hose to tank)

Clement is "just down the road," not across the country.

Clement's nationwide network of distributors means that Clement quality service and genuine Clement replacement parts are "just down the road," not across the country.

Frame

- Main Frame:** 13-inch, fabricated
- Draft Arms:** Fabricated
- Rollers:** (5) 5-inch OD, brass bushings with zerks
- Rails Outside:** 35-inch **Inside:** 27-inch
- Hoist Cylinder:** 73-102 double acting
- Container Tie Downs:** Ratchet binders - One set
- Front Nose Sheave:** 12-inch diameter, bushed
- Cable:** 3/4-inch x 86-feet with ring

Loading System

Reeving Cylinders: (provides pull to load approximately 54,000-pound container)
(2) 7-inch x 92.5-inch stroke

Hydraulic Oil Tank Required: 75-gallons

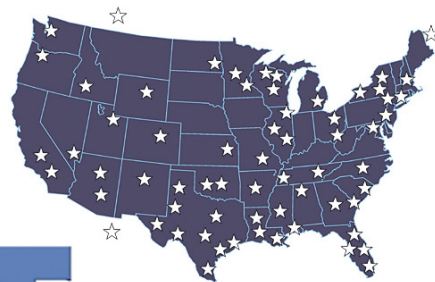

CLEMENT HiBit

P.O. Box 914, Minden, LA 71058-0914, www.clementind.com, Toll free: 800-562-5948